

IEFE

Centre for Research on Energy and Environmental Economics and Policy

Intra-State and Inter-State Congestion Management: a missing Point in the EU Market Integration Agenda?

Clara Poletti and Guido Cervigni

Florence, 29 January 2010

FSR Workshop: ERGEG's Regional Initiatives and the EU 3rd Legislative Package on Energy

Premise - 1

- National congestion management schemes have not been an item in the European electricity integration agenda:
 - The 2^o Package: Regulation 1228 (2003) on conditions for access to the network ...*for cross-border exchanges*
 - The 3^o Package: Regulation 714 (2009) ENTSO to elaborate network codes *for cross-border network issues and market integration issues*
- Discussions within the ERI process have been carried-out as if national and cross-border congestion management arrangements were independent.

Premise - 2

- What is the cost of un-harmonised national and cross border congestion management?
 - Total supply costs not minimised
 - Welfare transfers among countries and market participants
 - Distortion of competition cross borders
- Recently the issue has been tackled by the Commission within the Competition policy framework (“Swedish Interconnectors” Case).

Agenda

- The basics: redispatch-based and locational-price based congestion management systems
- Consequences of non-coordinated domestic and cross-border congestion management schemes
- Conclusion: why coordinating on national congestion management is so difficult?

Agenda

- **The basics: redispatch-based and locational-price based congestion management systems**
- Consequences of non-coordinated domestic and cross-border congestion management schemes
- Conclusion: why coordinating on national congestion management is so difficult?

The basics

- A quick refresh of the usual concepts:
 - Definition of transmission congestion
 - Redispatch
 - Allocation of a feasible set of transmission rights (AKA: market coupling, market splitting, locational pricing, implicit auction.....)
- Extremely simple examples for a very complicated issue!

Transmission Congestion

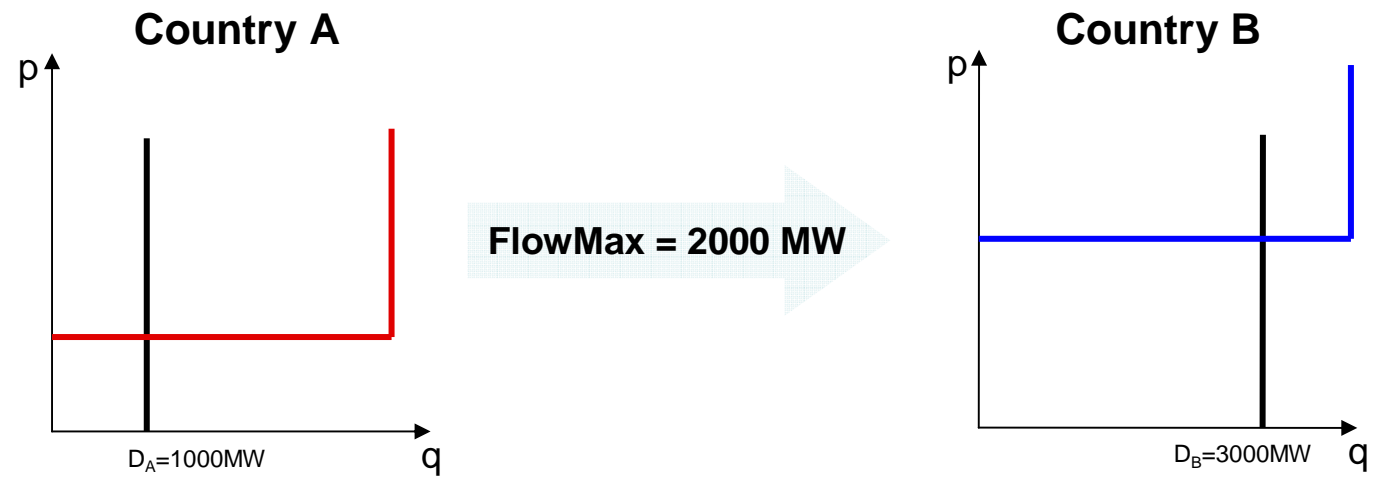

Congestion: unconstrained transactions would yield infeasible flows

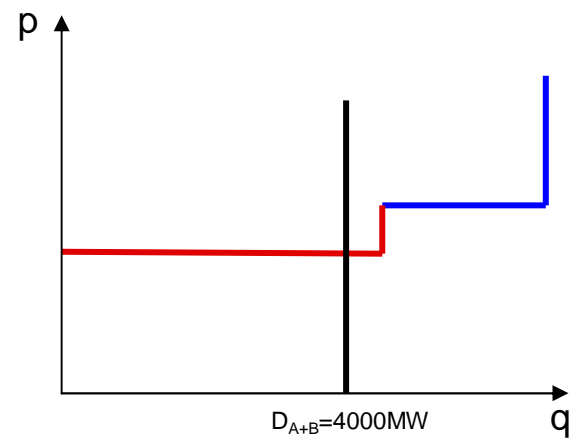

**Unconstrained Equilibrium
Flow = 3000 > FlowMax**



Congestion management via redispatch

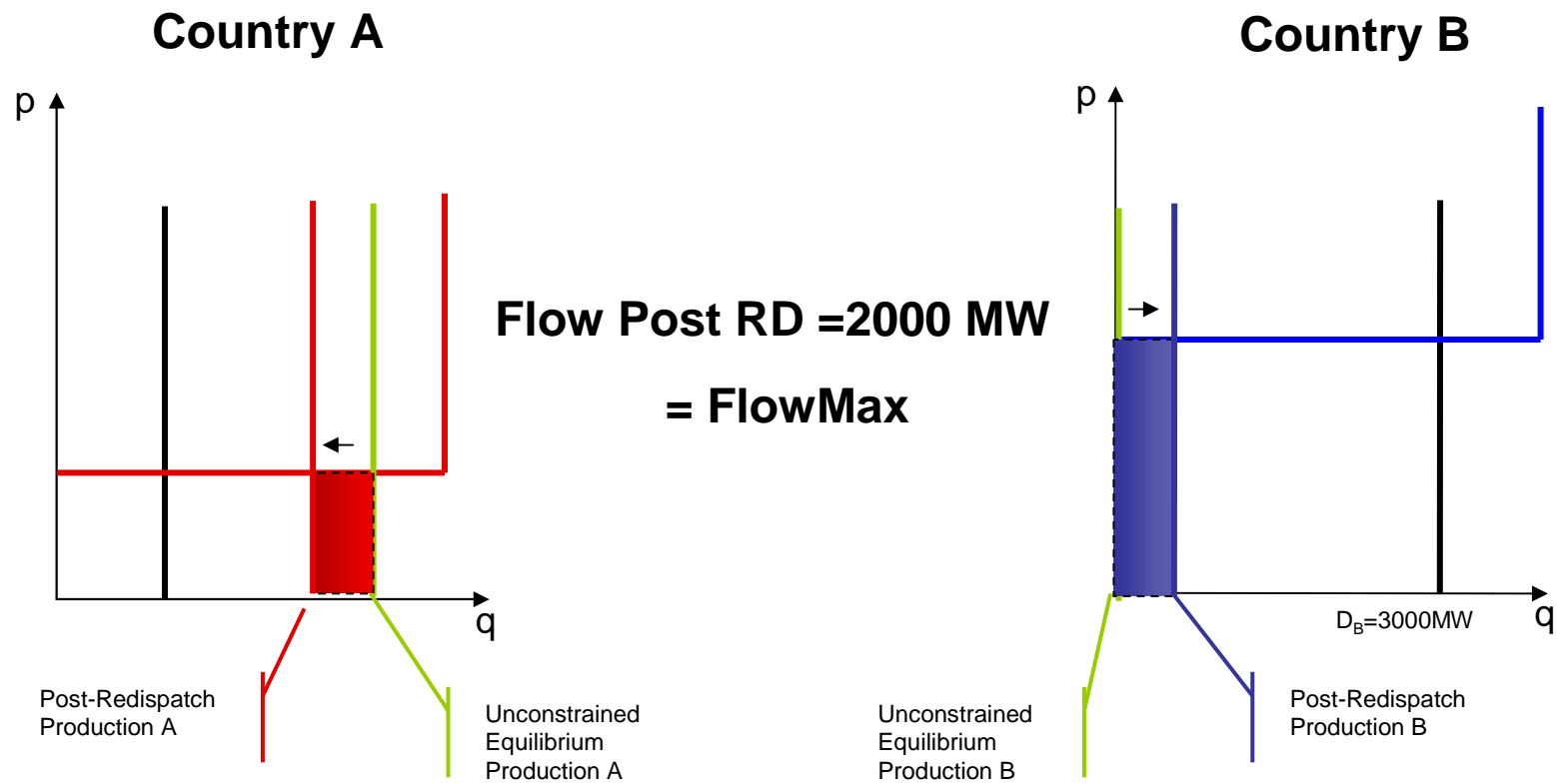

Congestion management via allocation of feasible transmission rights

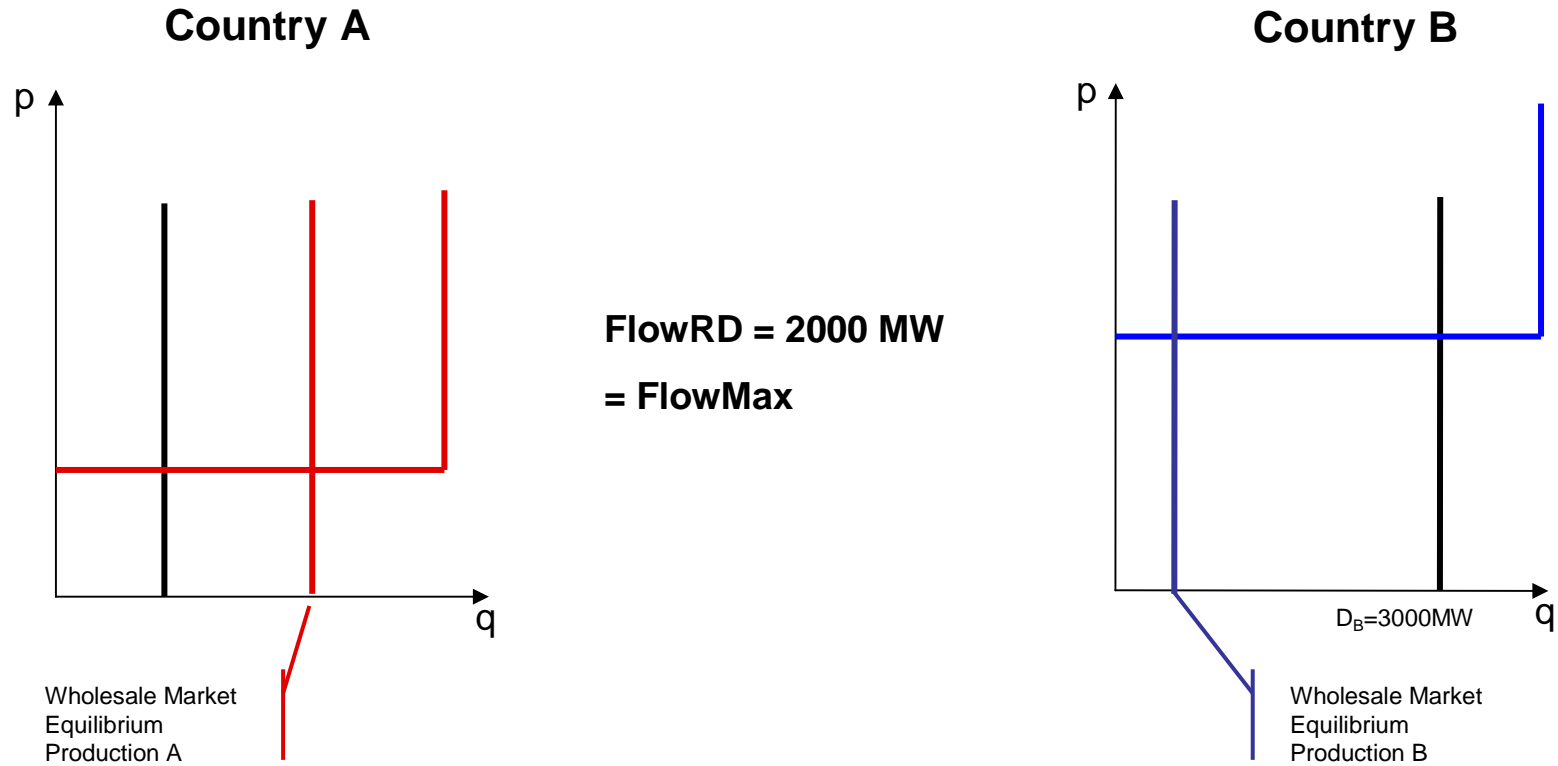

Wholesale market equilibrium yields feasible flows. Locational price differentiation in case of congestion

Agenda

- The basics: redispatch-based and locational-price based congestion management systems
- **Consequences of non-coordinated domestic and cross-border congestion management schemes**
- Conclusion: why coordinating on national congestion management is so difficult?

Implications of uncoordinated national and cross-border congestion management issues

- We discuss two issues:
 - Trade-off between redispatch costs and cross-border interconnection capacity in the classic NTC framework
 - Implications of the one-country/one-price constraint in a “flow based market-coupling” model
 - And show that the lack of harmonisation between national and cross-border congestion management generally result in:
 - inefficient dispatch
 - distributive effects among countries and within countries
 - discrimination among domestic and cross border transactions
- compared to the first-best benchmark

The trade-off between NTC and national redispatch - 1

The setting

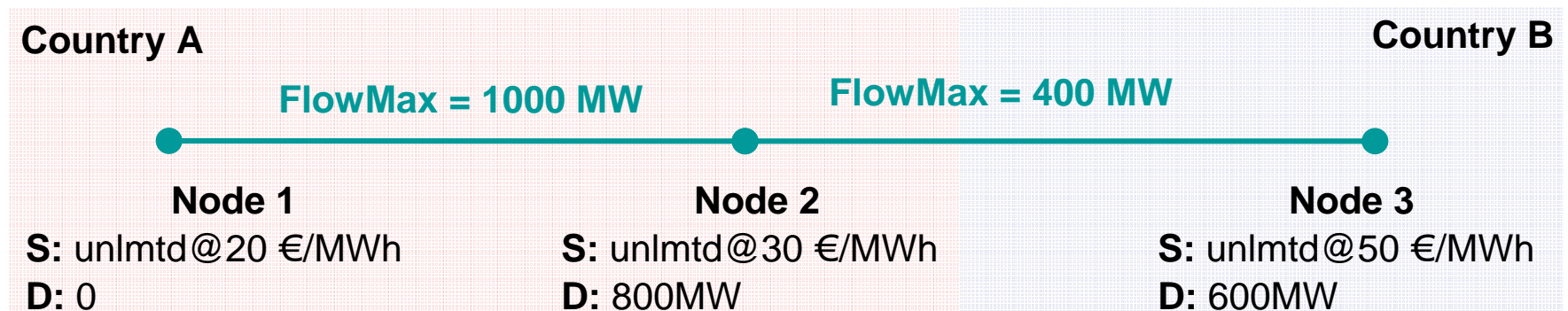

- Extra-simple setting:
 - Non-meshed network, no losses, identical lines, DC approximation
 - Inflexible demand
 - Unlimited supply at each node
- **National congestions managed via redispatch; cross-border via transmission rights**

The trade-off between NTC and national redispatch - 2

Market equilibrium with NTC=400

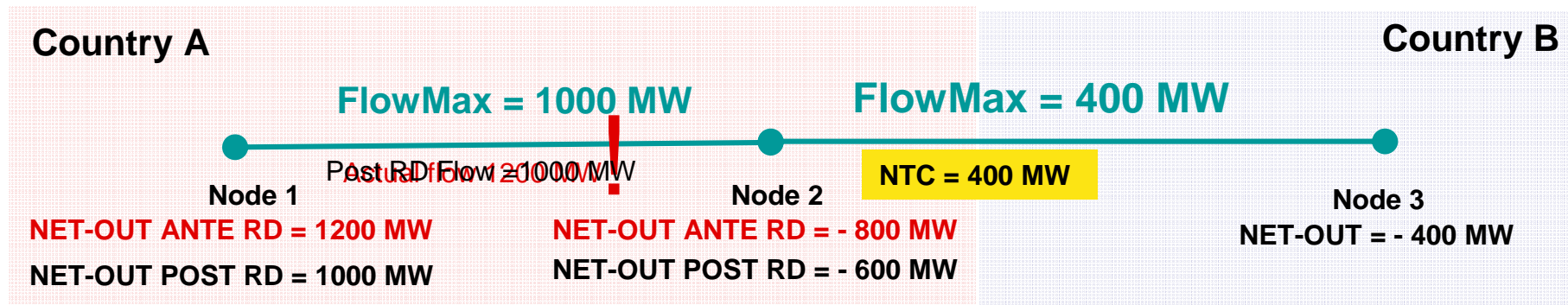

- Market outcome with NTC=400
 - Demand in Country A = $800 + NTC = 1200$,
 - All production in Node 1 (cheapest), $P_A = 20$, $P_B = 50$
 - Congestion on Node 1-Node 2 line
 - Need to redispatch 200 MW
 - Redispatch cost = $200 * (30 - 20)$ € paid by TSO-A

The trade-off between NTC and national redispatch - 2

Market equilibrium with NTC=200

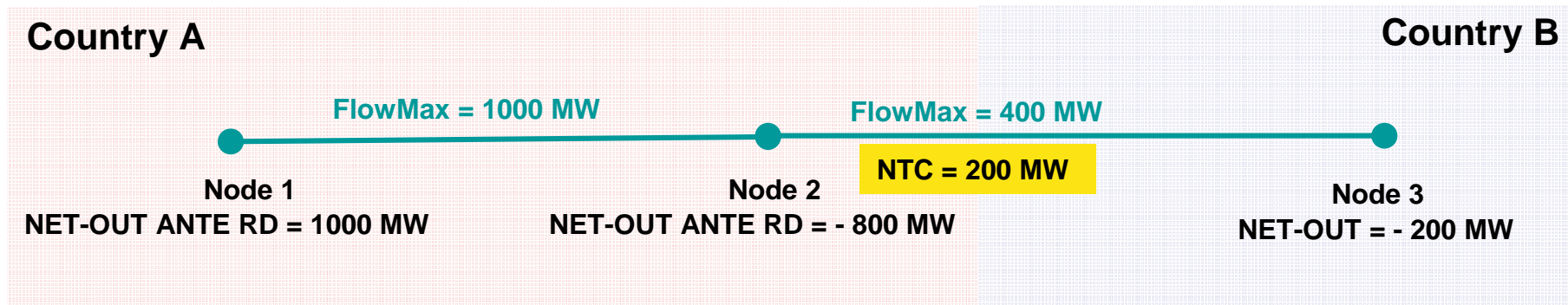

- Market outcome with NTC=200
 - Demand in Country A = $800 + \text{NTC} = 1000$,
 - All production in Node 1 (cheapest), $P_A = 20$, $P_B = 50$
 - No congestion and no redispatch cost



The trade-off between NTC and national redispatch - 3

The Commission's reading of the situation (Swedish Interconnectors Case)

- An Article 82 (now 102) Case:
 - TSO-A is in a dominant position
 - By lowering the NTC TSO-A is discriminating national and cross border transactions

The trade-off between NTC and national redispatch - 4

The Swedish TSO's commitments

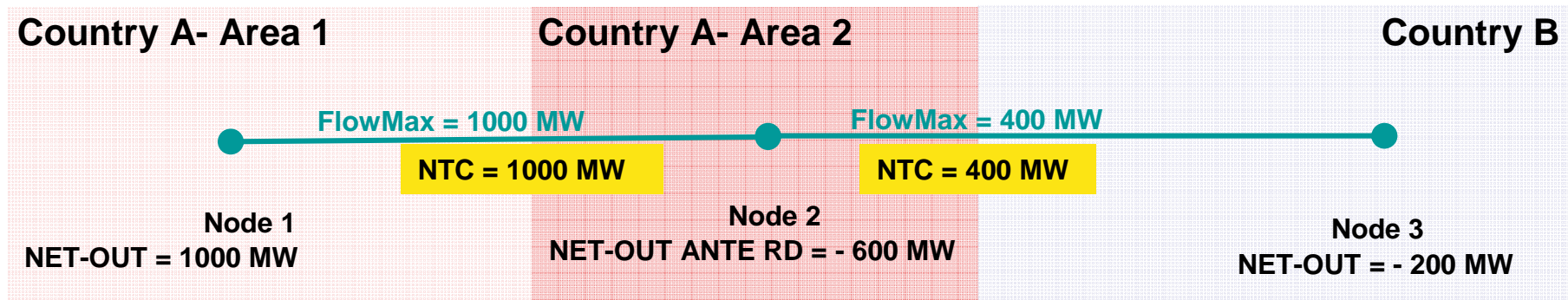

- Uniform national and cross-border congestion management system
 - Define intra-Country bidding Areas and NTCs
 - Allow different wholesale market equilibrium prices in different Areas
- Efficient market outcome, no redispatch
 - PA-1=20, PA2=30, PB=50

The trade-off between NTC and national redispatch - 5

Assessment

- By lowering the NTC, TSO-A saves on redispatch cost...
- ..and the cross border congestion rent decreases
- The market outcome is inefficient
- Profits for generators in A and B change when NTC changes
- Prices would change when NTC changes in a realistic setting

A simplified network for Market Coupling - 1

The setting

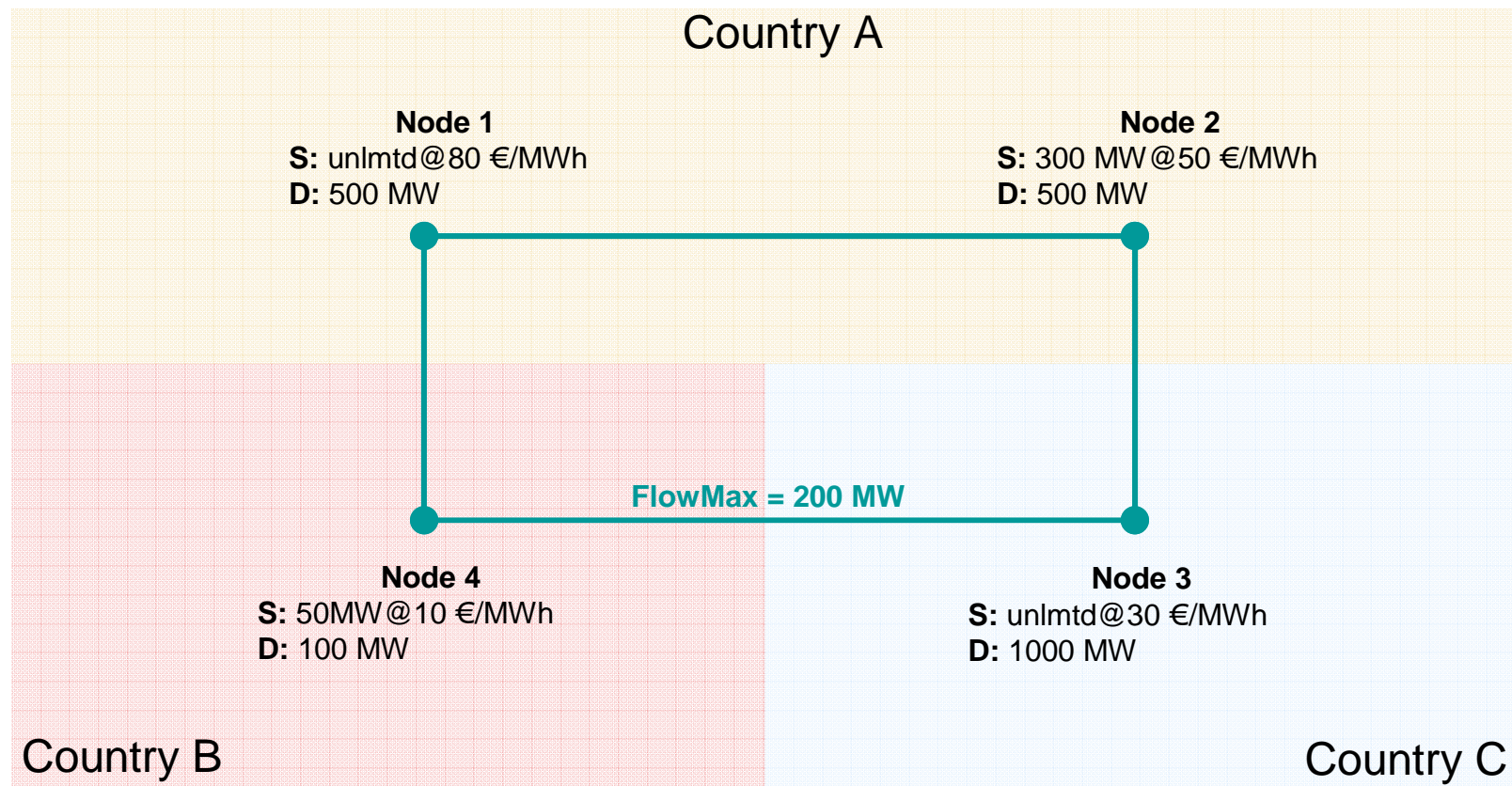

PTDF on Line 34	Node 1	Node 2	Node 4
(Node 3 is swing)	-1/2	-1/4	-3/4

A simplified network for Market Coupling - 2

First-best: integrated national & cross-border cong. managmnt

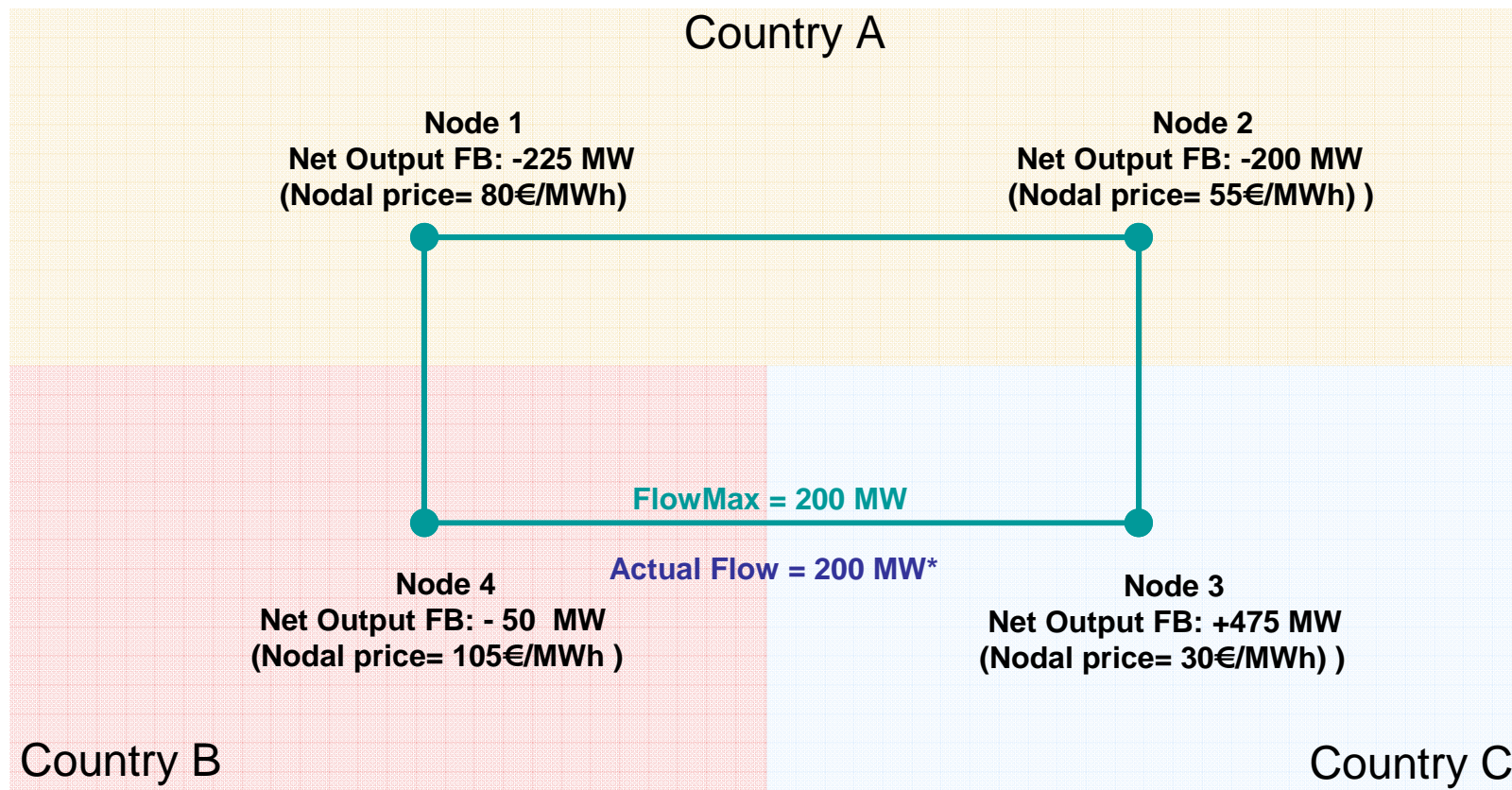

$$\text{Actual Flow}_{43} = 200 \text{ MW} = 50 \cdot (3/4) + 225 \cdot (1/2) + 200 \cdot (1/4)$$

A simplified network for Market Coupling - 3

Market Coupling under the one-Country one-price constraint

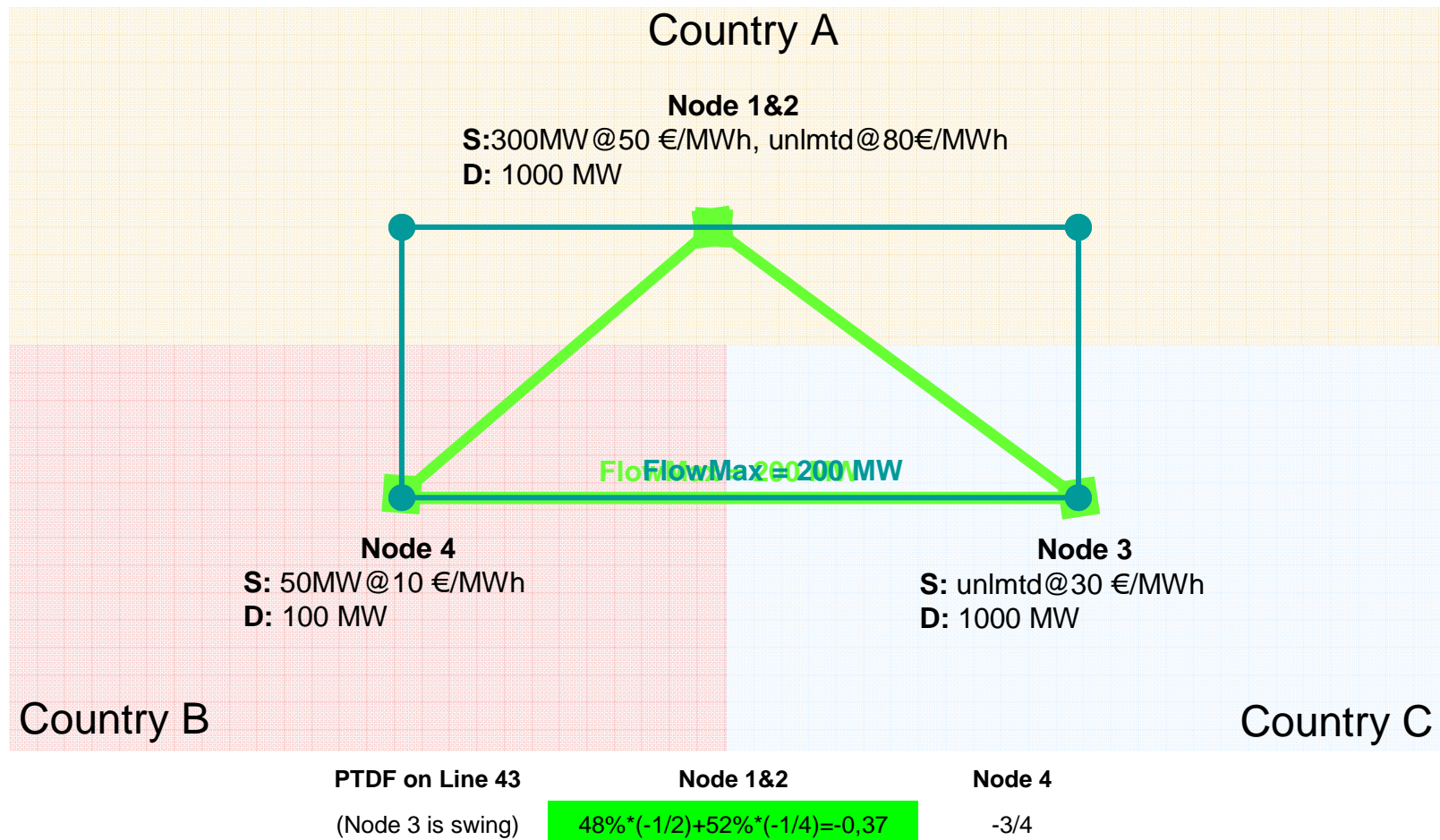

These PTDF for the simplified network are “the best you can get” ...

A simplified network for Market Coupling - 4

FBMC Market Outcome

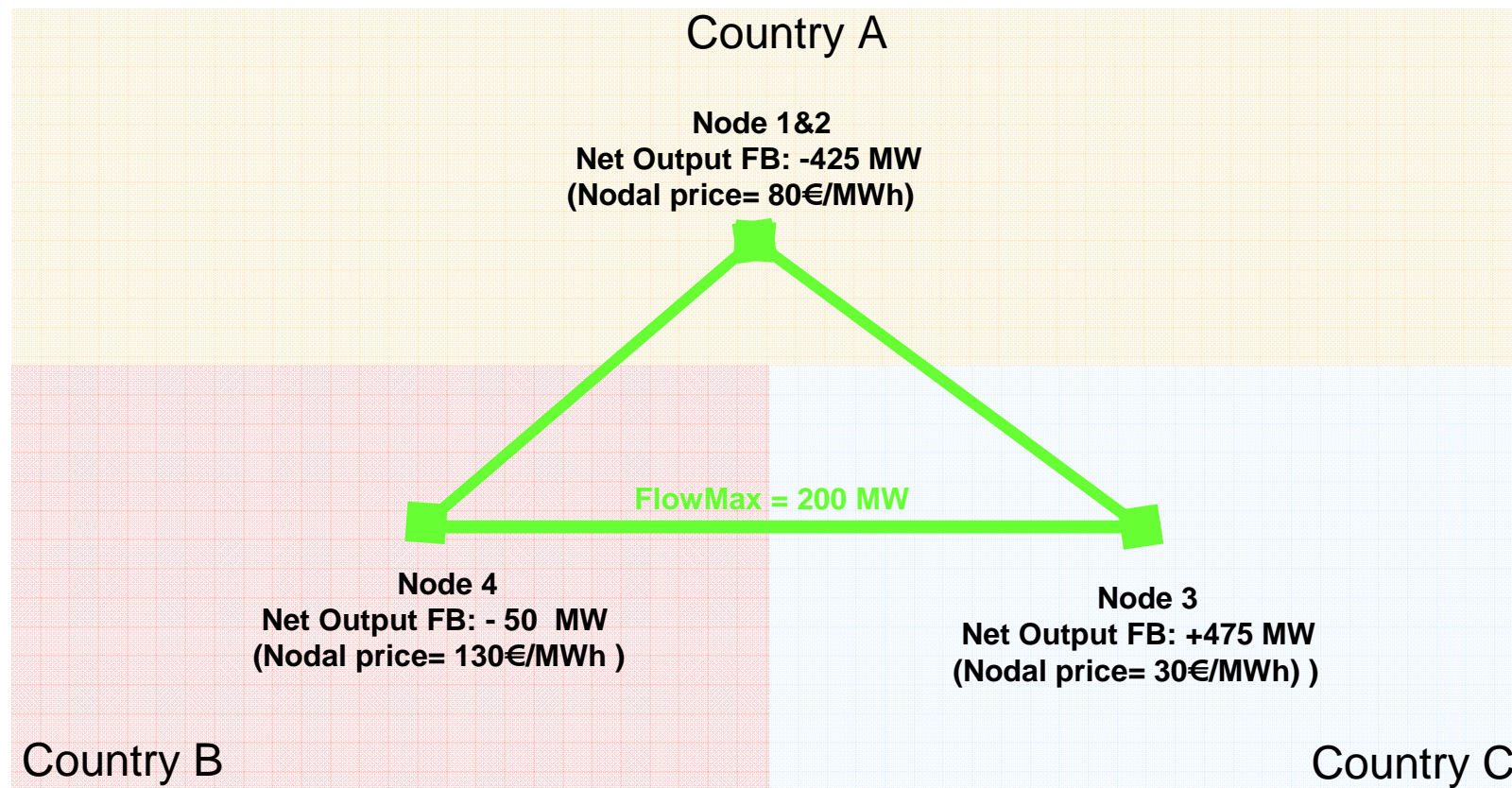

$$\text{Actual Flow}_{34} = 200 \text{ MW} = -50 * (-3/4) - 425 * (-0,37)$$

A simplified network for Market Coupling - 5

Summary of results

Nodal			FBMC "best" simplification	
Node	P	Net-Flows	P	Net-Flows
	€/MWh	MWh	€/MWh	MWh
1	80	-225	80	-425
2	55	-200	30	475
3	30	475	130	-50
4	105	-50		
Flow on line 34		200	200	

FBMC PTDF = average of nodal PTDFs
weighted by nodal net-flows

- The “best” FBMC approx. yields “wrong” prices
- The “marginal PTDF” approx. yields inefficient dispatch and congestion
- And both methods assume omniscient TSOs...

Agenda

- The basics: redispatch-based and locational-price based congestion management systems
- Consequences of non-coordinated domestic and cross-border congestion management schemes
- **Conclusion: why coordinating on national congestion management is so difficult?**

Why coordination of cross-border and national congestion system is so difficult?

- Moving to locational prices within a State might be politically difficult:
 - Historically extensive price-averaging featured in utility pricing
 - The value of some generators might change materially after the move to locational prices
- Some obstacles may be overcome:
 - Italy (and some US markets): demand-side uniform price

Is the third Package going to help?

- “ENTSO to elaborate network codes *for cross-border network issues and market integration issues*”
- It remains to be seen if – in practice – national congestion management (as other aspects of system operations like for example reserve procurement, balancing ...) will be recognised and dealt-with as a *cross-border network issue and/or a market integration issue*



Clara Poletti

IEFE, Bocconi University
via Roentgen 1, Milan
clara.poletti@unibocconi.it

Guido Cervigni

LECG Italy
piazzale Biancamano 8, Milan
gcervigni@lecg.com